



PSEN cs6.11n

PILZ
THE SPIRIT OF SAFETY

► PSEN sensor technology

This document is the original document.

All rights to this documentation are reserved by Pilz GmbH & Co. KG. Copies may be made for the user's internal purposes. Suggestions and comments for improving this documentation will be gratefully received.

Source code from third-party manufacturers or open source software has been used for some components. The relevant licence information is available on the Internet on the Pilz homepage.

Pilz®, PIT®, PMI®, PNOZ®, Primo®, PSEN®, PSS®, PVIS®, SafetyBUS p®, SafetyEYE®, SafetyNET p®, the spirit of safety® are registered and protected trademarks of Pilz GmbH & Co. KG in some countries.



SD means Secure Digital

Introduction	5
Validity of documentation	5
Using the documentation	5
Definition of symbols	5
Safety	6
Intended use	6
Safety regulations	7
Safety assessment	7
Use of qualified personnel	7
Warranty and liability	7
Disposal	7
For your safety	8
Unit features	8
Function description	9
Block diagram	9
Operating distances	9
Lateral and vertical offset	11
Wiring	13
Pin assignment, connector and cable	13
Connection to evaluation devices	14
Single connection	14
Connection to Pilz evaluation devices	14
Teaching in the actuator	16
Installation	16
Use in operating heights higher than 2000 m above sea level	19
Adjustment	19
Operation	19
Normal mode	20
Error display	20
Dimensions in mm	21
Technical details	23
Safety characteristic data	25
Supplementary data	26
Radio approval	26

Order reference	26
System	26
Accessories	27
EC declaration of conformity	28

Introduction

Validity of documentation

This documentation is valid for the product PSEN cs6.11n. It is valid until new documentation is published.

This operating manual explains the function and operation, describes the installation and provides guidelines on how to connect the product.

Using the documentation

This document is intended for instruction. Only install and commission the product if you have read and understood this document. The document should be retained for future reference.

Definition of symbols

Information that is particularly important is identified as follows:



DANGER!

This warning must be heeded! It warns of a hazardous situation that poses an immediate threat of serious injury and death and indicates preventive measures that can be taken.



WARNING!

This warning must be heeded! It warns of a hazardous situation that could lead to serious injury and death and indicates preventive measures that can be taken.



CAUTION!

This refers to a hazard that can lead to a less serious or minor injury plus material damage, and also provides information on preventive measures that can be taken.



NOTICE

This describes a situation in which the product or devices could be damaged and also provides information on preventive measures that can be taken. It also highlights areas within the text that are of particular importance.

**INFORMATION**

This gives advice on applications and provides information on special features.

Safety**Intended use**

The safety functions of the safety switch are:

- ▶ Safe shutdown of safety outputs when the actuator is removed beyond the assured release distance s_{ar} or when the actuator is not detected
- ▶ Remain shut down safely after the actuator has been removed

The safety switch meets the requirements in accordance with:

- ▶ EN 60947-5-3: PDDb with the actuator PSEN cs6.11 M12
- ▶ EN 62061: SIL CL 3
- ▶ EN ISO 13849-1: PL e (Cat. 4)
- ▶ EN ISO 14119: Coding level High, type 4

The safety switch may only be used with the corresponding actuator PSEN cs6.11 M12.

The safety level PL e (Cat. 4)/SIL CL 3 is only achieved if

- ▶ the safety outputs use 2-channel processing.

The following is deemed improper use in particular

- ▶ Any component, technical or electrical modification to the product,
- ▶ Use of the product outside the areas described in this manual,
- ▶ Use of the product outside the technical details (see [Technical details](#)  23)).

**NOTICE****EMC-compliant electrical installation**

The product is designed for use in an industrial environment. The product may cause interference if installed in other environments. If installed in other environments, measures should be taken to comply with the applicable standards and directives for the respective installation site with regard to interference.

Safety regulations

Safety assessment

Before using a device it is necessary to perform a safety assessment in accordance with the Machinery Directive.

Functional safety is guaranteed for the product as a single component. However, this does not guarantee the functional safety of the overall plant/machine. In order to achieve the required safety level for the overall plant/machine, define the safety requirements for the plant/machine and then define how these must be implemented from a technical and organisational standpoint.

Use of qualified personnel

The products may only be assembled, installed, programmed, commissioned, operated, maintained and decommissioned by competent persons.

A competent person is a qualified and knowledgeable person who, because of their training, experience and current professional activity, has the specialist knowledge required. To be able to inspect, assess and operate devices, systems and machines, the person has to be informed of the state of the art and the applicable national, European and international laws, directives and standards.

It is the company's responsibility only to employ personnel who

- ▶ Are familiar with the basic regulations concerning health and safety / accident prevention,
- ▶ Have read and understood the information provided in the section entitled Safety
- ▶ Have a good knowledge of the generic and specialist standards applicable to the specific application.

Warranty and liability

All claims to warranty and liability will be rendered invalid if

- ▶ The product was used contrary to the purpose for which it is intended,
- ▶ Damage can be attributed to not having followed the guidelines in the manual,
- ▶ Operating personnel are not suitably qualified,
- ▶ Any type of modification has been made (e.g. exchanging components on the PCB boards, soldering work etc.).

Disposal

- ▶ In safety-related applications, please comply with the mission time T_M in the safety-related characteristic data.
- ▶ When decommissioning, please comply with local regulations regarding the disposal of electronic devices (e.g. Electrical and Electronic Equipment Act).

For your safety**DANGER!**

Risk of malfunction of pacemakers or implanted defibrillators

The magnetic field of the safety switch may cause malfunctions of pacemakers or implanted defibrillators.

People with a pacemaker or implanted defibrillators must maintain a distance of at least 100 mm to the safety switch and actuator.

**WARNING!**

Loss of safety function due to manipulation of the interlocking device

Manipulation of the interlocking device may lead to serious injury and death.

- You should prevent any possibility of the interlocking device being manipulated through the use of a spare actuator.
- Keep the substitute actuator in a safe place and protect it from unauthorised access.
- If spare actuators are used, these must be installed as described in [Installation](#) [📖 16].
- If the original actuators are replaced with substitute actuators, the original actuators must be destroyed before disposal.

- ▶ Do not remove the connector's protective cap until you are just about to connect the unit. This will prevent potential contamination.

Unit features

- ▶ Transponder technology for presence detection
- ▶ Pilz coding type: fully coded
- ▶ Dual-channel operation
- ▶ 2 safety outputs
- ▶ 1 signal output
- ▶ Magnetic latching with permanent magnet, (holding force 30 N)
- ▶ LED display for:
 - State of the actuator
 - State of the inputs (always lights up yellow)
 - Supply voltage/fault
- ▶ 1 actuation direction with 3 approach directions (see [Explanation of markings](#) [📖 9])
 - Square marking

The guaranteed safe operating distances for the specified selections only apply when the actuator approaches the switch vertically. With other approach directions, the operating distances may partly be considerably larger.

Function description

The safety outputs may have a high or low signal, depending on the position of the actuator.

State of the outputs:

Actuator in the response range	Safety output 12	Safety output 22	Signal output Y32
Yes	High	High	High
No	Low	Low	Low

Block diagram

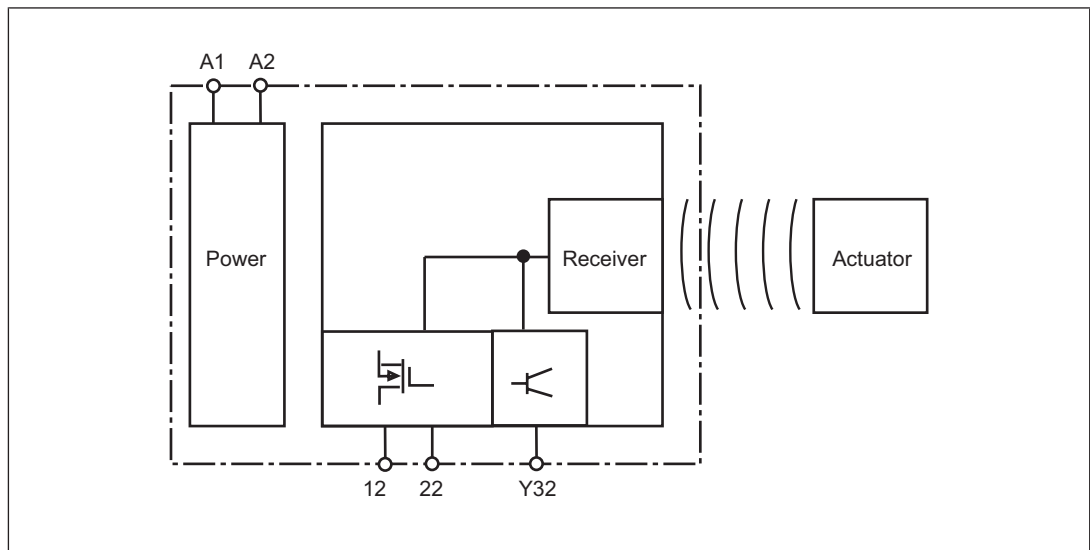

Operating distances

Alignment of the actuator	Operating distances
	<p>[1] Actuator aligned to the square marking on the switch</p> <p>S_{ao} Assured operating distance: 8 mm</p> <p>S_{ar} Assured release distance: 20 mm</p> <p>S_o Typical operating distance: 11 mm</p> <p>S_r Typical release distance: 14 mm</p>

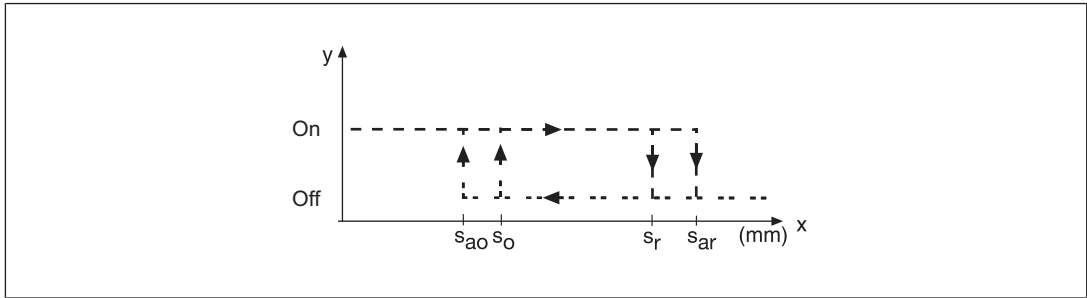

Typical course of change in the holding force as the distance from the switch to the actuator increases with frontal approach

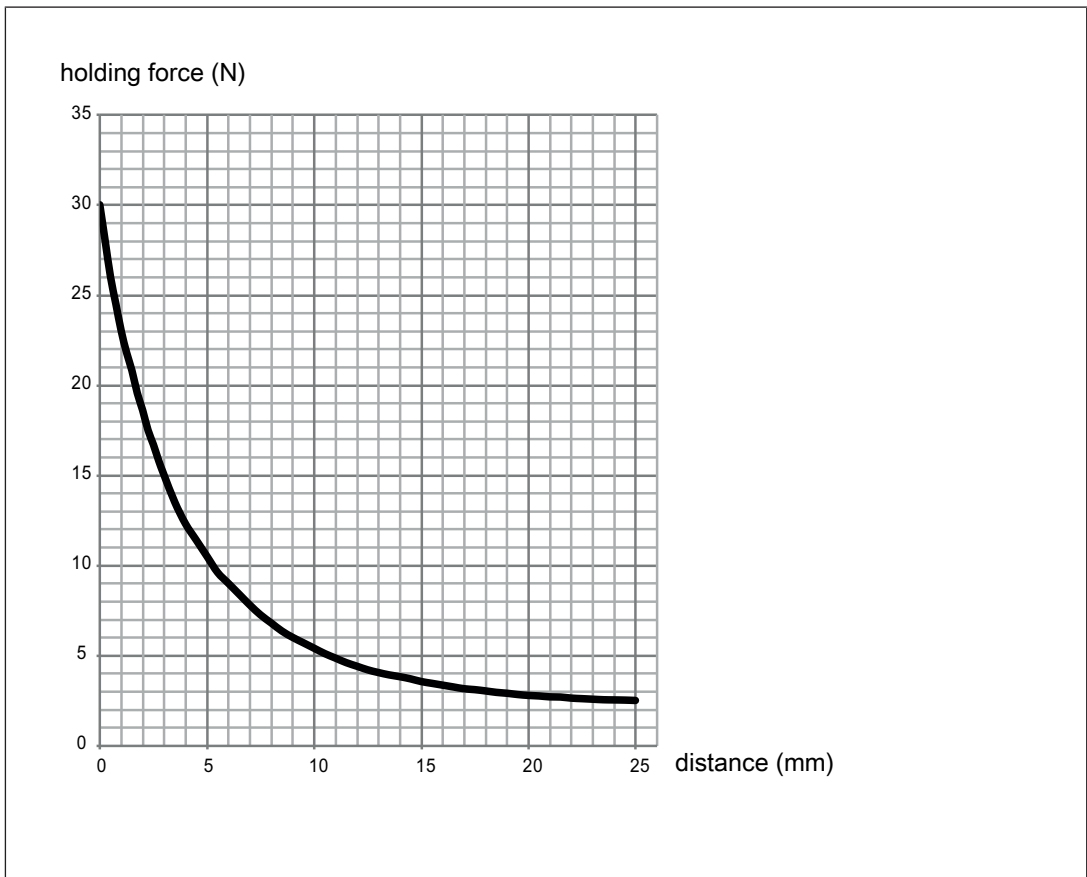
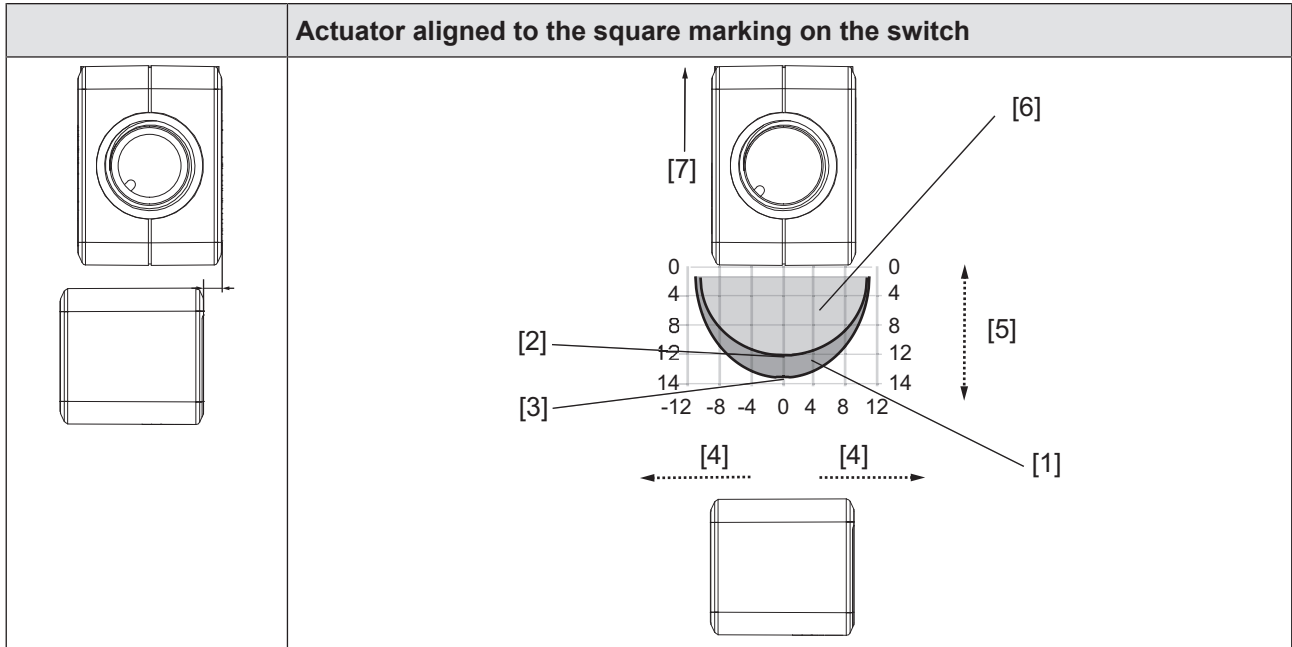

Fig.: Change in the holding force for distances from 0-25 mm

Lateral and vertical offset

Lateral offset when aligning to the triangle marking



Legend

- [1] Hysteresis
- [2] Typical operating distance S_o
- [3] Typical release distance S_r
- [4] Offset in mm
- [5] Operating distance in mm
- [6] Response range
- [7] Status of LED

Lateral offset when aligning to the triangle marking

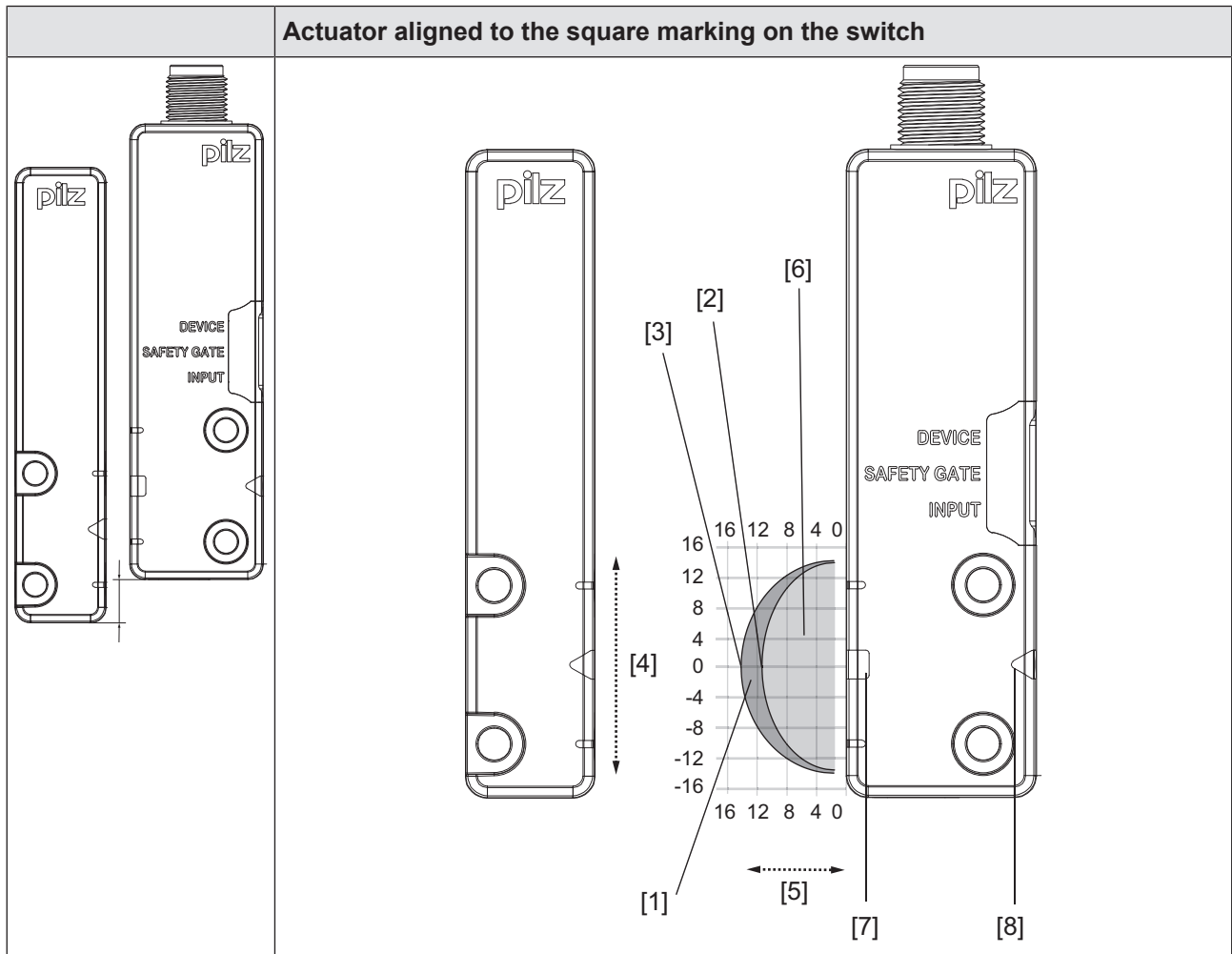

Legend

- [1] Hysteresis
- [2] Typical operating distance S_o
- [3] Typical release distance S_r
- [4] Offset in mm
- [5] Operating distance in mm
- [6] Response range
- [7] Status of LED
- [8] Square marking

Wiring

Please note:

- ▶ Information given in the "Technical details" must be followed.
- ▶ The power supply must meet the regulations for extra low voltages with protective separation (SELV, PELV).
- ▶ The inputs and outputs of the safety switch must have a protective separation to voltages over 60 VDC.



INFORMATION

Only use safety relays with a 24 VDC supply voltage. Safety relays with a wide-range power supply or in AC device versions have internal potential isolation and are not suitable as evaluation devices.

- ▶ The supply voltage to the safety switch must be protected with a 2 A to 4 A quick-acting fuse.
- ▶ Ensure the wiring and EMC requirements of EN 60204-1 are met.

Pin assignment, connector and cable

	5-pin M12 male connector
--	--------------------------

PIN	Pin designation	Function	Wire colour
1	A1	+24 V UB	brown
2	12	Output, channel1	white
3	A2	0 V UB	blue
4	22	Output, channel2	black
5	Y32	Signal output	grey

The wire colour also applies for the cable available from Pilz as an accessory.

Connection to evaluation devices

Make sure that the selected evaluation device has the following properties:

- ▶ 2-channel with feasibility monitoring
- ▶ OSSD signals are evaluated

Single connection



CAUTION!

Do not connect the signal output to 0 V!

If the signal output Y32 is connected to 0 V, the safety switch may be damaged as a result. Connect the signal output Y32 to a consumer, e.g. to the input on a control system, or leave the signal output unconnected. Also note the max. current (see [Technical details](#) [ 23]).

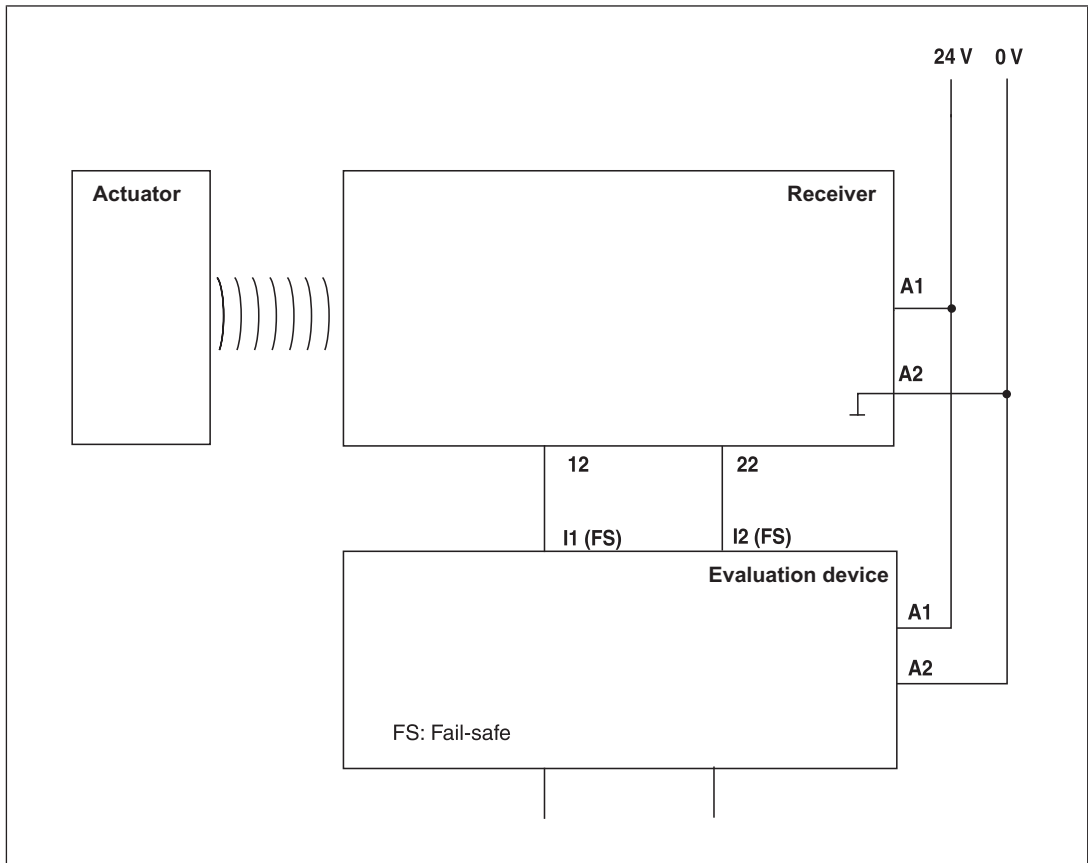

Connection to Pilz evaluation devices

The safety switch PSEN cs6.11n can be connected to Pilz evaluation devices, for example.

Suitable Pilz evaluation devices are, for example:

- ▶ PNOZelog for safety gate monitoring
- ▶ PNOZpower for safety gate monitoring
- ▶ PNOZsigma for safety gate monitoring

- ▶ PNOZ X for safety gate monitoring
- ▶ PNOZmulti for safety gate monitoring
Configure the switch in the PNOZmulti Configurator with switch type 3.
- ▶ PSS for safety gate monitoring with standard function block SB064, SB066 or FS_Safety Gate

The correct connection to the respective evaluation device is described in the operating manual for the evaluation device. Make sure that the connection is made in accordance with the specifications in the operating manual for the selected evaluation device.

The connections to two evaluation devices are shown on the following pages, by way of example:

- ▶ PNOZ s3 and
- ▶ PNOZmulti

PNOZ s3

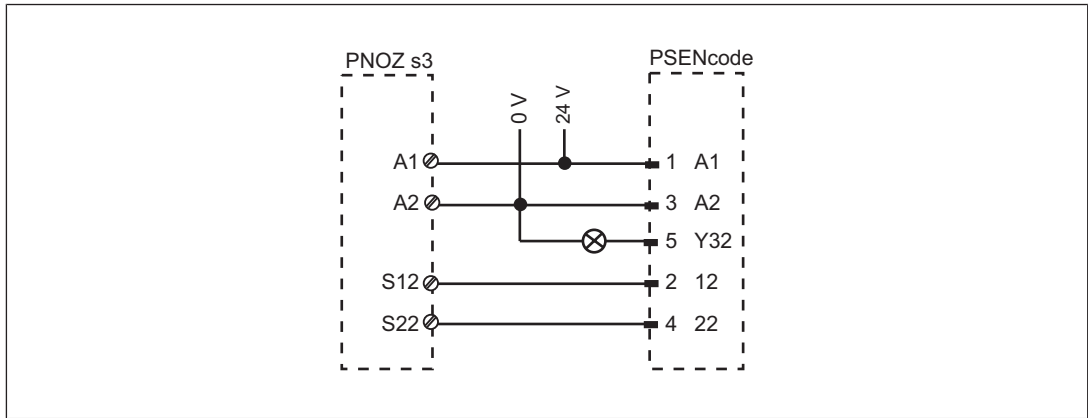

PNOZmulti

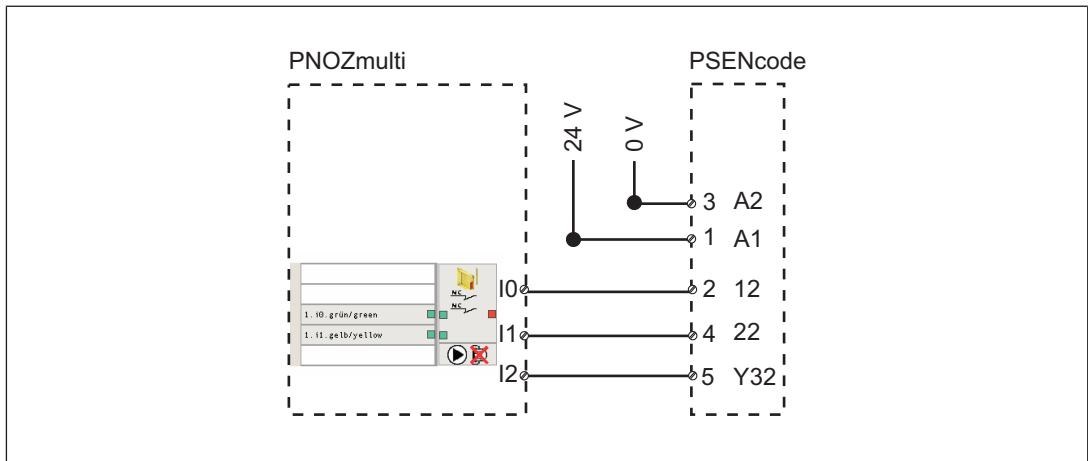

Legend:

I0	Input OSSD
I1	Input OSSD
I2	Signal input

Teaching in the actuator

Teaching in the actuator for the first time:

The first actuator PSEN cs6.11 M12 detected by the safety switch is automatically taught in as soon as it is brought into the response range.

To teach in a new actuator:

- ▶ A maximum of 8 learning procedures are possible.
- 1. The actuator that is to be taught in must be brought into the safety switch's response range as the only transponder. As soon as the actuator is detected, the "Safety Gate" LED will flash yellow (see [LED status, teach-in actuator](#) [ 20]).
- 2. After 20 s has elapsed, the "Safety Gate" LED turns to quick yellow flashes. Trigger a system reset in the next 120 s by interrupting the power supply.
- 3. When the supply voltage is switched back on, the learning procedure is complete and the number of permitted additional learning procedures is reduced by 1.



NOTICE

- The actuator must not be removed during the learning procedure.
- This actuator cannot be retaught on the same safety switch.

Installation





CAUTION!

Potential loss of safety function due to changed device properties

The unit's properties may be affected if installed in an environment containing electrically or magnetically conductive material.

- Please check the operating distances and the assured release distance.

- ▶ The safety switch and actuator should be installed opposite each other in parallel. Make sure that the actuator is aligned to the square marking on the sensor (see [Operating distances](#) [ 9]).
- ▶ Safety switches and actuators should only be secured using M4 screws with a flat head (e.g. M4 cheese-head or pan head screws).
- ▶ Torque setting: Please note the information provided under [Technical details](#) [ 23].
- ▶ The distance between two safety switches must be maintained (see [Technical details](#) [ 23]).
The distance can be undershot in certain application cases (see diagrams).

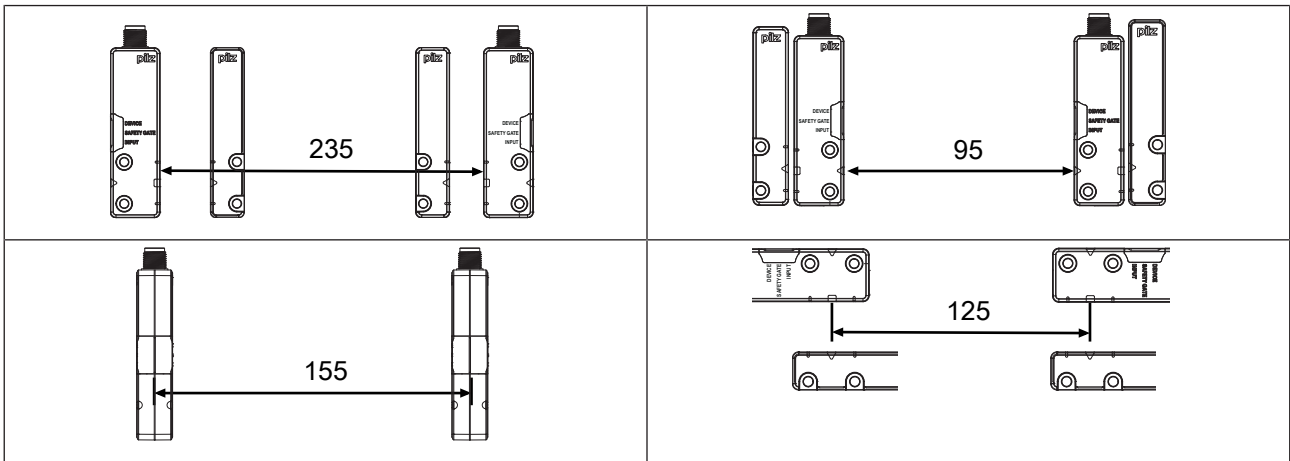

- ▶ If using angled connector plugs, note the defined angle of the cable routing.
- ▶ When installing make sure you comply with the requirements of EN ISO 14119.
- ▶ Make sure that the safety switch and actuator cannot be used as an end stop.
- ▶ For simpler installation, the mounting brackets (see [Order reference for Accessories \[27\]](#)) can be used.
- ▶ The actuator should be protected from unauthorised removal and from contamination. Close the mounting holes using the seals provided (see diagrams). The use of seals should be regarded as equivalent to using permanent fastenings in accordance with Clause 7.2c of EN ISO 14119.

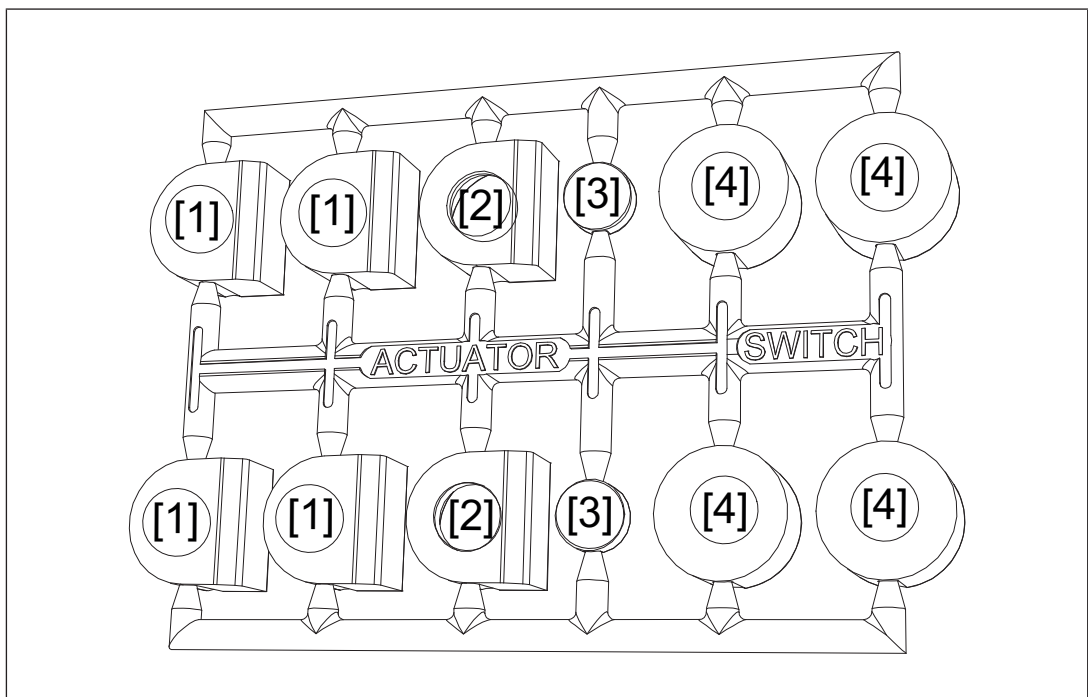

Fig.: Seals

- [1]: 4 seals for actuators
- [2]: 2 seals for actuators
- [3]: 2 seals for actuators
- [4]: 2 seals for switches and 2 seals for actuators

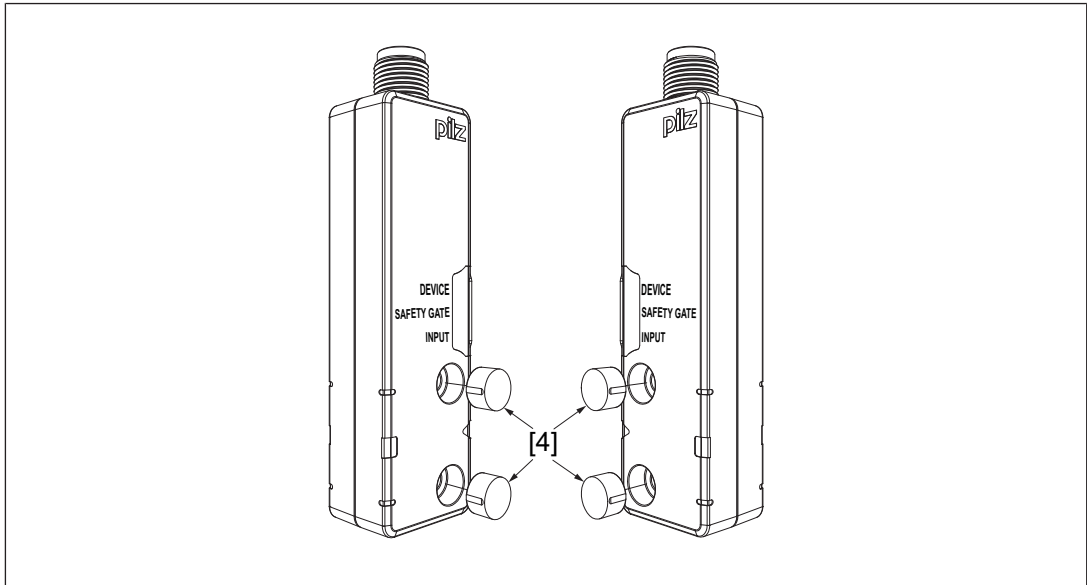

Fig.: Applying the screw cover [4] on the switch

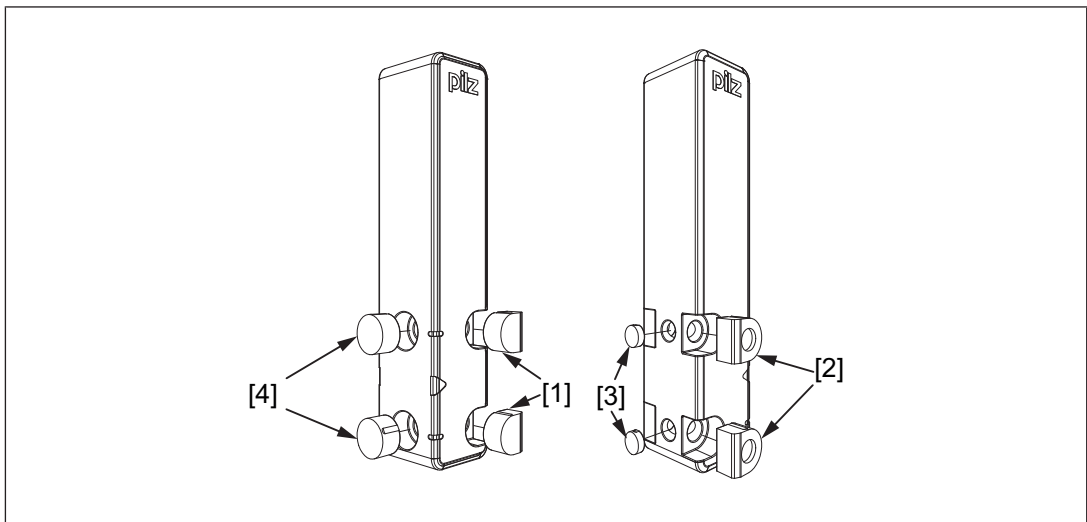



Fig.: Applying the screw covers [1] and [3] on the actuator

Procedure:

1. Drill holes (for M4 screws) in the mounting surface to secure the actuator and sensor (see [Dimensions in mm](#)  21).
2. Use a screw to fix the sensor to the mounting surface.
Make sure that the square marking on the sensor can be operated using the actuator from the right side.
3. Do not fully tighten the second screw on the safety switch.
4. Use a screw to fix the actuator to the mounting surface.
Make sure that the actuator with the triangle marking points towards the triangle marking on the sensor.
5. Do not fully tighten the second screw on the actuator.

6. Align the safety switch and tighten the screws.
7. Align the actuator and tighten the screws.

Use in operating heights higher than 2000 m above sea level

When using the PSEN cs6.11n note the reduced max. ambient temperature of +60 °C at a height of 2000 m to 4000 m.

Adjustment

- ▶ The stated operating distances (see [Technical details](#) [📖 23]) only apply when the safety switch and actuator are installed facing each other in parallel. Operating distances may deviate if other arrangements are used.
- ▶ Note the maximum permitted lateral and vertical offset (see [Operating distances](#) [📖 9] and [Lateral and vertical offset](#) [📖 11]).

Operation



NOTICE



The safety function should be checked after initial commissioning and each time the plant/machine is changed. The safety functions may only be checked by qualified personnel.

Status indicators:





Legend:

	LED off
	LED on
	LED flashes (500 ms on, 500 ms off)
	LED flashes quickly (50 ms on, 950 ms off)
	LED flashes very quickly (30 ms on, 470 ms off)









Normal mode

LED status		Switch status
Device	 green	Ready for operation
Safety gate	 yel- low	Actuator is within the response range
	● Off	Actuator is outside the response range
Input	 yel- low	The unit is ready for operation

LED display actuator teach-in

LED status			Switch status	Remedy / measure
Device	Safety Gate	Input		
 Green	 yellow	Display not definitive	Teaching actuator. Duration approx. 20 seconds	-
 Green	 yellow	Display not definitive	Actuator teach-in complete.	Switch voltage off and then on again.

Error display

LED status			Switch status	Remedy / measure
Device	Safety Gate	Input		
 red	● Off	● Off	Internal error on switch	Change the switch.
 red	 yellow	 yellow	Supply voltage is outside the tolerance range	Ensure the voltage supply corresponds to the Technical details [23] .
 yellow	Display not definitive	Display not definitive	Supply voltage is at the limit of the tolerance range	Ensure the voltage supply corresponds to the Technical details [23] .
 red	Display of last status	Display of last status	Outputs in fault condition	Check the outputs and switch the voltage off and then on again.
 green	 yellow	Display not definitive	Wrong actuator	Use the actuator PSEN cs6.11 M12.

LED status			Switch status	Remedy / measure
Device	Safety Gate	Input		
● Off	● yellow	● yellow	Switch doesn't start	Change the switch.

Dimensions in mm

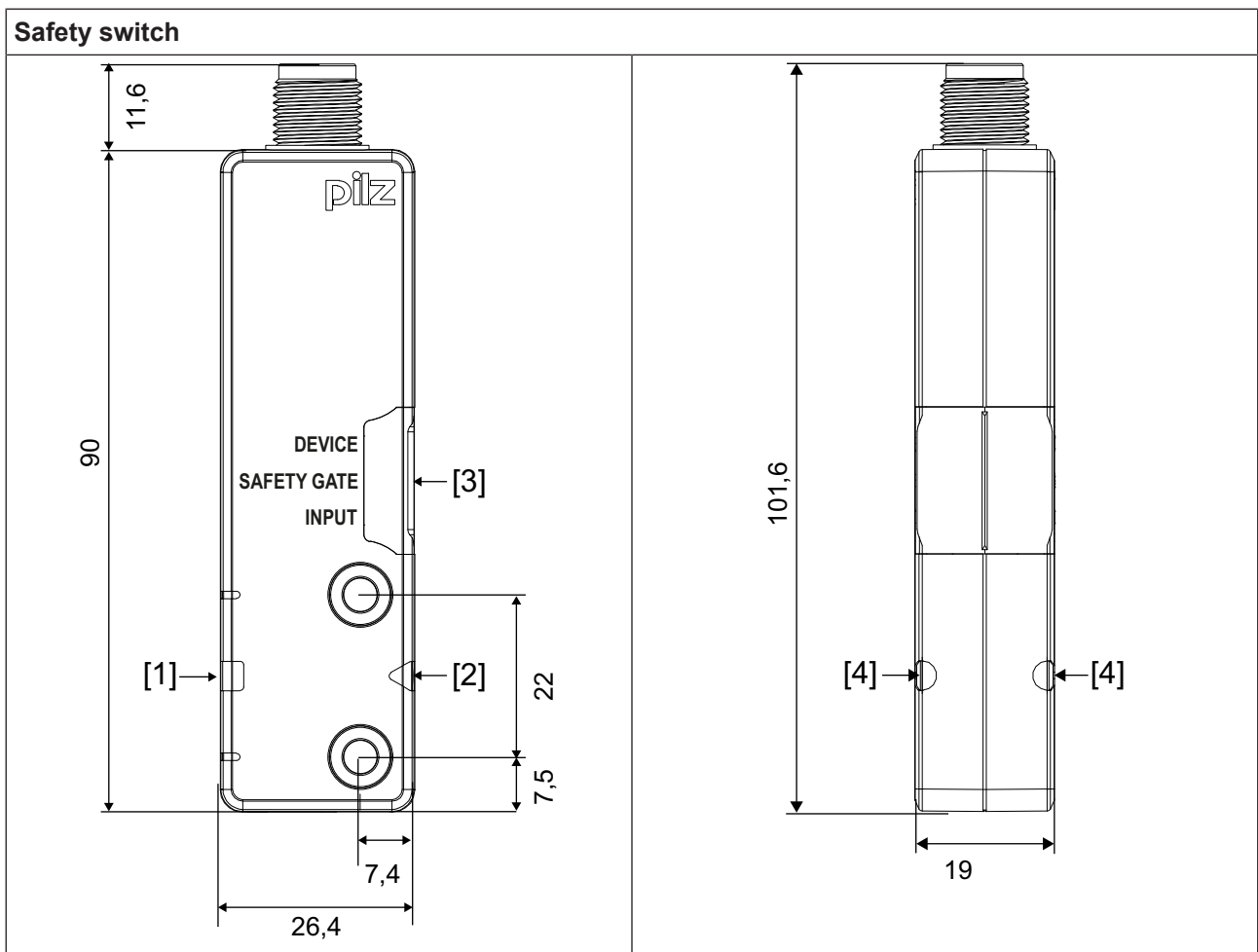

Actuator

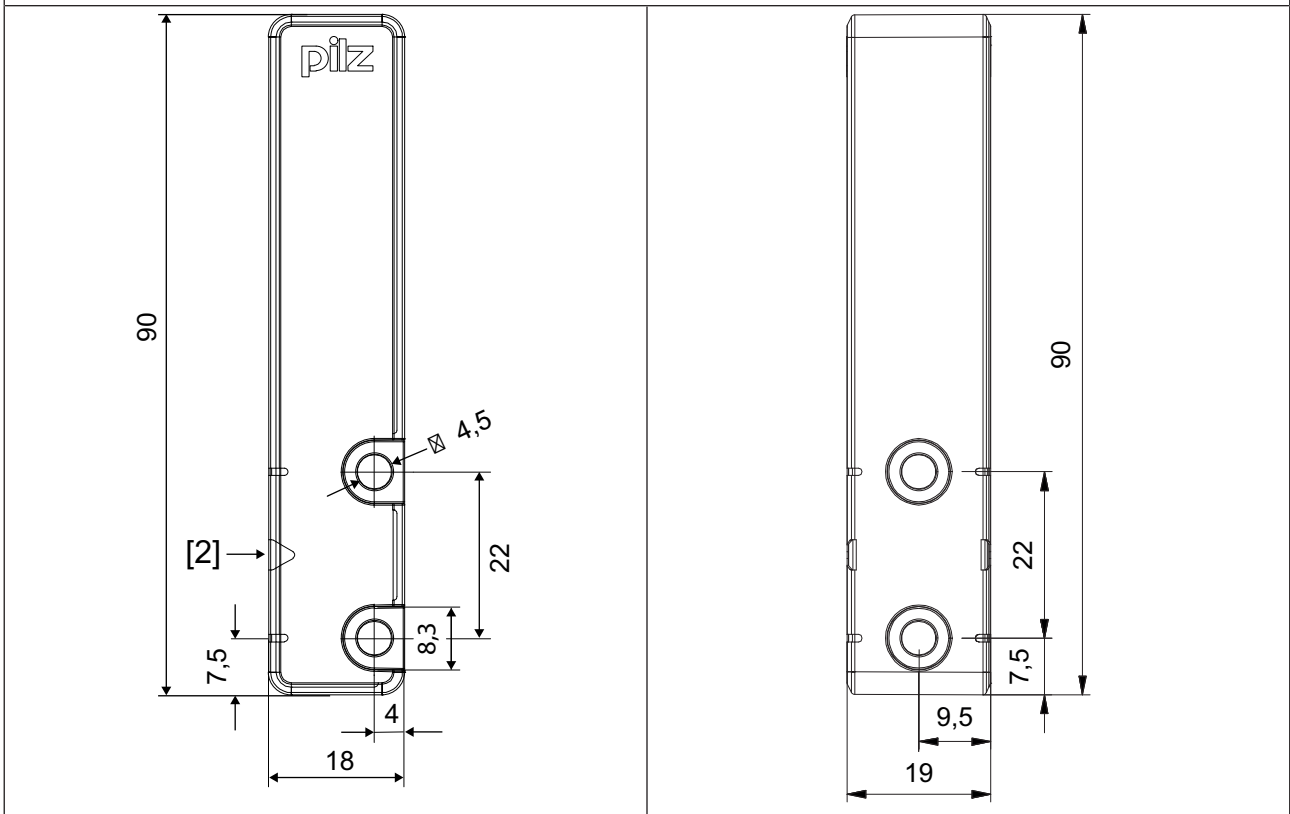

Legend:

- [1] Square marking
- [2] Triangle marking
- [3] LEDs
- [4] Semicircle marking

Technical details

General	
Approvals	CE, EAC (Eurasian), ECOLAB, FCC, IC, TÜV, UL/cUL
Sensor's mode of operation	Transponder
Coding level in accordance with EN ISO 14119	High
Design in accordance with EN ISO 14119	4
Classification in accordance with EN 60947-5-3	PDDB
Pilz coding type	fully coded
Transponder	
Frequency band	122 kHz - 128 kHz
Max. transmitter output	15 mW
Electrical data	
Supply voltage	
Voltage	24 V
Kind	DC
Voltage tolerance	-20 %/+20 %
Output of external power supply (DC)	1 W
Max. switching frequency	3 Hz
Max. cable capacitance at the safety outputs	
No-load, PNOZ with relay contacts	40 nF
PNOZmulti, PNOZelog, PSS	40 nF
Max. inrush current impulse	
Current pulse, A1	0,5 A
No-load current	25 mA
Semiconductor outputs	
OSSD safety outputs	2
Signal outputs	1
Switching current per output	100 mA
Breaking capacity per output	2,4 W
Potential isolation from system voltage	No
Short circuit-proof	yes
Residual current at outputs	400 µA
Voltage drop at OSSDs	1 V
Conditional rated short circuit current	100 A
Lowest operating current	2 mA
Utilisation category in accordance with EN 60947-1	DC-12
Times	
Test pulse duration, safety outputs	150 µs
Switch-on delay	
after UB is applied	1 s
Actuator typ.	30 ms
Actuator max.	50 ms

Times	
Delay-on de-energisation	
Actuator typ.	30 ms
Actuator max.	40 ms
Risk time in accordance with EN 60947-5-3	150 ms
Supply interruption before de-energisation	20 ms
Simultaneity, channel 1 and 2 max.	∞
Environmental data	
Ambient temperature	
In accordance with the standard	EN 60068-2-14
Temperature range	-25 - 70 °C
Max. at max. operating height	+60 °C
Max. at max. operating height <2000 m	+70 °C
Storage temperature	
In accordance with the standard	EN 60068-2-1/-2
Temperature range	-40 - 85 °C
Climatic suitability	
In accordance with the standard	EN 60068-2-30
Humidity	93 % r. h. at 40 °C
Max. operating height above sea level	4000 m
EMC	EN 60947-5-3
Vibration	
In accordance with the standard	EN 60947-5-2
Frequency	10 - 55 Hz
Amplitude	1 mm
Shock stress	
In accordance with the standard	EN 60947-5-2
Acceleration	30g
Duration	11 ms
Airgap creepage	
Overvoltage category	III
Pollution degree	3
Rated insulation voltage	75 V
Rated impulse withstand voltage	1 kV
Protection type	
Housing	IP66, IP67
Mechanical data	
Magnetic holding force between actuator and sensor	30 N
Actuator 1	PSEN cs6.11 M12
Operating distances	
Repetition accuracy switching distances	3 %
Change of operating distance with temperature changes	+0,02mm/°C

Mechanical data

Operating distances when the actuator approaches square marking

Assured operating distance S_{ao}	8 mm
Assured release distance S_{ar}	20 mm
Typical operating distance S_o	11 mm
Typical release distance S_r	14 mm
Typical hysteresis	2 mm

Min. distance between safety switches **250 mm**

Sensor flush installation in accordance with EN 60947-5-2

Yes, follow installation guidelines

Connection type

M12, 5-pin male connector

Material

PA+GF, PBT, polycarbonate

Max. torque setting for fixing screws

1 Nm

Dimensions

Height	26,4 mm
Width	101,6 mm
Depth	19 mm

Actuator dimensions

Height	18 mm
Width	90 mm
Depth	19 mm

Weight of safety switch

75 g

Weight of actuator

60 g

Weight

135 g

Where standards are undated, the 2015-11 latest editions shall apply.

Safety characteristic data**NOTICE**

You must comply with the safety-related characteristic data in order to achieve the required safety level for your plant/machine.

Operating Mode	EN ISO 13849-1: 2015 PL	EN ISO 13849-1: 2015 Category	EN 62061 SIL CL	EN 62061 PFH _D [1/h]	IEC 61511 SIL	IEC 61511 PFD	EN ISO 13849-1: 2015 T _M [year]
2-ch. OSSD	PL e	Cat. 4	SIL CL 3	9,56E-10	–	8,51E-06	20

All the units used within a safety function must be considered when calculating the safety characteristic data.



INFORMATION

A safety function's SIL/PL values are **not** identical to the SIL/PL values of the units that are used and may be different. We recommend that you use the PAScal software tool to calculate the safety function's SIL/PL values.

Supplementary data

Radio approval

USA/Canada

FC FCC ID: VT8-PSENC55
IC: 7482A-PSENC55

FCC/IC-Requirements:

This product complies with Part 15 of the FCC Rules and with Industry Canada licence-exempt RSS standards.

Operation is subject to the following two conditions:

- 1) this product may not cause harmful interference, and
- 2) this product must accept any interference received, including interference that may cause undesired operation.

Changes or modifications made to this product not expressly approved by Pilz may void the FCC authorization to operate this equipment.

NOTE: This equipment has been tested and found to comply with the limits for a Class A digital device, pursuant to Part 15 of the FCC Rules. These limits are designed to provide reasonable protection against harmful interference when the equipment is operated in a commercial environment. This equipment generates, uses, and can radiate radio frequency energy and, if not installed and used in accordance with the instruction manual, may cause harmful interference to radio communications. Operation of this equipment in a residential area is likely to cause harmful interference in which case the user will be required to correct the interference at his own expense.

Le présent produit est conforme aux CNR d'Industrie Canada applicables aux appareils radio exempts de licence. L'exploitation est autorisée aux deux conditions suivantes:

- (1) le produit ne doit pas produire de brouillage, et
- (2) l'utilisateur de le produit doit accepter tout brouillage radioélectrique subi, même si le brouillage est susceptible d'en compromettre le fonctionnement.

Order reference

System

Product type	Features	Connection type	Order no.
PSEN cs6.11n/PSEN cs6.11 M12	Safety gate system with magnetic latching, fully coded	5-pin M12 connector	542 113
PSEN cs6.11n 1switch	Safety switch, fully coded, with magnet	5-pin M12 connector	542 163
PSEN cs6.11 M12 1actuator	Actuator, coded, with magnet		542 181

Accessories

Installation materials

Product type	Features	Order no.
PSEN bracket	Mounting bracket	532 110
PSEN mag/cs bracket straight	Mounting aid	532 111
PSEN screw M4x20 10pcs	Safety screws made from stainless steel with one-way slot	540 313
PSEN screw M4x26 10pcs	Safety screws made from stainless steel with one-way slot	540 314
PSEN cs1/2 bracket cable fix	Mechanical protection against defeat, protecting against unauthorised cable disconnection or damage for safety switches PSENcode cs1/2, PSENcode cs5/6 M12, PSENslock	532 112

Cable

Product type	Connection 1	Connection 2	Length	Order No.
PSS67/PDP67 cable M12-5sf	Straight, M12, 5-pin, socket	Straight, M12, 5-pin, connector	3 m	380 208
			5 m	380 209
			10 m	380 210
			20 m	380 220
			30 m	380 211
PSS67/PDP67 cable M12-5af	Angled, M12, 5-pin, socket	Angled, M12, 5-pin, connector	3 m	380 212
			5 m	380 213
			10 m	380 214
			30 m	380 215
PSEN cable M12-5sf	Straight, M12, 5-pin, socket	Open cable	3 m	630 310
			5 m	630 311
			10 m	630 312
			20 m	630 298
			30 m	630 297
PSEN cable M12-5af	Angled, M12, 5-pin, socket	Open cable	3 m	630 347
			5 m	630 348
			10 m	630 349
			30 m	630 350

Connection

Product type	Features	Order no.
PDP67 F 8DI ION	Decentralised input module IP67 for PNOZmulti with M12 thread	773 600
PDP67 F 8DI ION HP	Decentralised input module IP67 for PNOZmulti with M12 thread and additional supply voltage	773 601
PDP67 F 8DI ION VA	Decentralised input module IP67 for PNOZmulti with M12 thread in stainless steel	773 614
PDP67 F 8DI ION HP VA	Decentralised input module IP67 for PNOZmulti with M12 thread in stainless steel and additional supply voltage	773 615

EC declaration of conformity

This product/these products meet the requirements of the following directives of the European Parliament and of the Council.

- ▶ 2006/42/EC on machines
- ▶ 2014/53/EC on radio equipment

The complete EC Declaration of Conformity is available on the Internet at www.pilz.com/downloads.

Representative: Norbert Fröhlich, Pilz GmbH & Co. KG, Felix-Wankel-Str. 2, 73760 Ostfildern, Germany